



# Hypercentric ball valve

Technical brochure

# 1. COMPANY PROFILE

AMPO is an **international leader** in highly engineered valves and Integrated Smart Solutions for the most severe applications and industries as well as in stainless steel and high alloy castings.

Through our AMPO SERVICE team **we guarantee a prompt response** to customer needs wherever they are throughout the world: technical support in start-up stages, equipment selection, predictive and preventive maintenance, training, etc.



Fully inhouse manufacturing process



Worldwide references



Project based on people



Innovative spirit



700+ people



In more than 60 countries



Most important partners in the industry



Cutting edge technologies



Our commitment: the best service



Customer focus



Since 1964



## 2. APPLICATION

Hypercentric ball valves may be suitable for several applications, such as:

- High temperature service
- Molecular sieve application
- Mesh filters application
- Contaminated fluids
- Coal mining
- Sea water cooling systems
- Hot tapping
- Cryogenic service
- Flowlines
- Dryer switching
- Suction and discharge isolation
- Heat transfer fluids/hot oil



### 3. HYPERCENTRIC BALL VALVE

**Sizes:** 2" up to 36"

**Pressure:** 150 lbs up to 2500 lbs

**Temperature:** -196°C up to 427°C

**Design type:** Split body or Top entry

**Standards:** API 6D, API 6FA, ASME B16.5, EN ISO 15156, NACE MR0175, IOGP, API 598

**Main material options:** CS body + 13Cr trim  
CS body + SS trim  
CS body 625 weld overlay + DSS trim  
CS body 625 weld overlay + 625 trim  
A105, A105N, A350 LF2, A182 F22, A182 F316, A182 F51, INCONEL 625  
Any other material composition available upon request

**End connections:** RF and/or BW

**Actuation:** Optimized Quarter Turn operation.  
Options: Manual, electric, pneumatic, hydraulic.

**Configuration:**

- Unidirectional and bidirectional seal
- Valve can be installed either in horizontal or vertical configuration
- Fully metallic configuration (up to 427°C)
- Low friction PTFE bush (up to 200°C)

**Other technical features:**

- Torque seated valve
- Standard API 6D bore and face-to-face dimensions
- Power Train Safety Factor larger than 2
- Quarter turn ball valve
- Fully piggable bore
- Serviceable in field with interchangeable parts (no need to adapt sealing components)
- Favorable torque characteristic, requiring high torque only near the fully closed position





## 4. WHY CHOOSE OUR HYPERCENTRIC BALL VALVES?

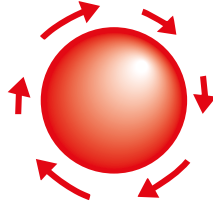

Friction free design and metal to metal sealing  
**EXTEND THE VALVE LIFE**, also at high temperature applications. (>750°F)



### **COST SAVING**

due to a selection of **CRA** weld overlay cladding applications and no material limitations.



### **FAST TRACK DELIVERY**

due to our fully in-house manufacturing capabilities.



### **LOW FUGITIVE EMISSIONS,**

achieving a **ZERO LEAKAGE** solution at preferential seal direction, with no galling in the rotating parts, and also increasing plant safety.



### **MAINTENANCE FREE LONG SERVICE LIFE**

due to a non-rising stem design. It is a true piggable valve.



Its quick operation, a robust design meeting API monogram specifications and its intrinsically fire safe design led to the **MOST RELIABLE VALVE SOLUTION.**

## 5. TECHNICAL FEATURES

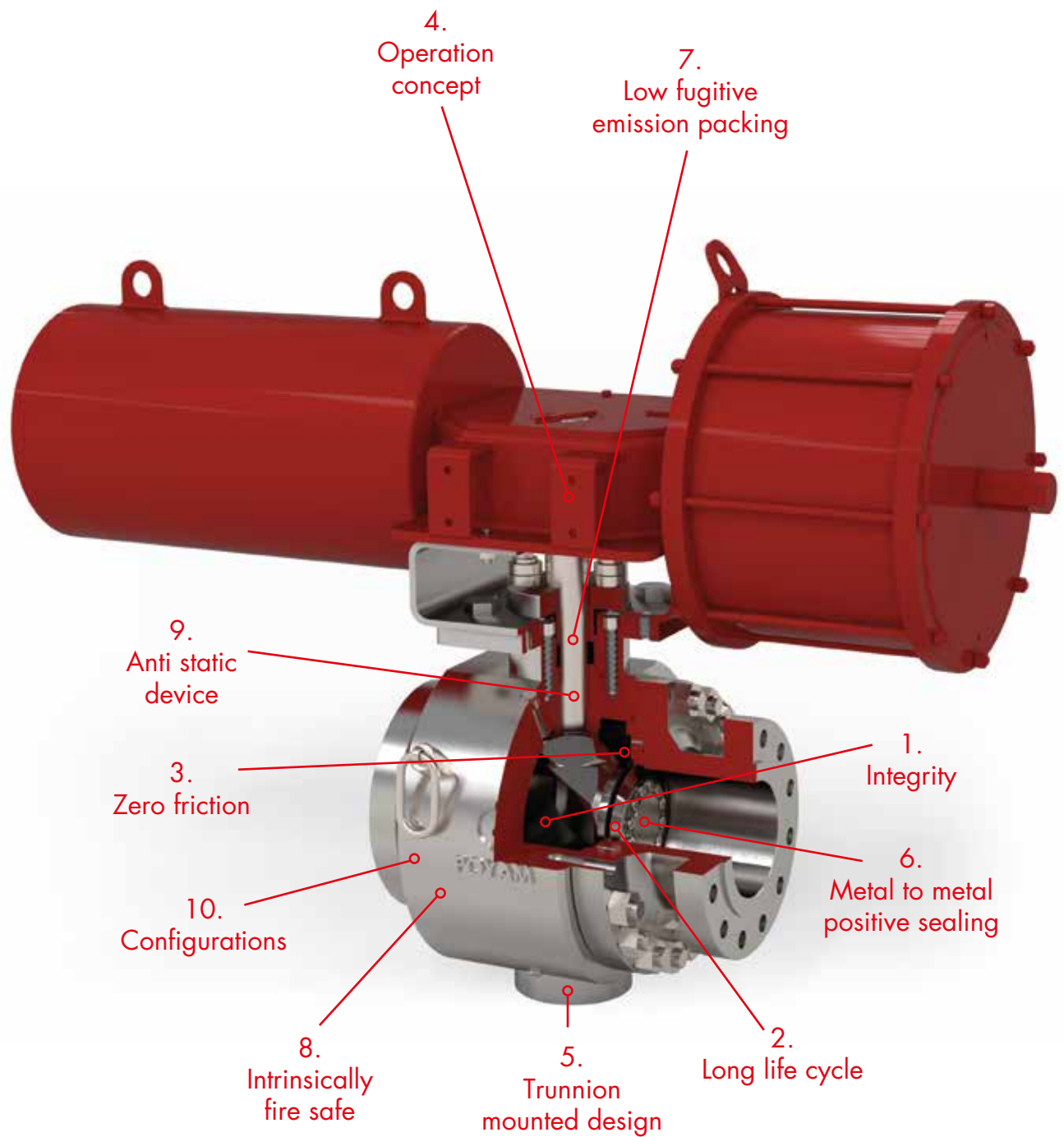

### 5.1 INTEGRITY:

- Sealing.
- Robust design. Two times safety factor is applied to stem size.
- Hypercentric ball valve is a torque seating metal seated ball valve with sealing element derived from conical surfaces. The design generates a positive sealing independent of the pressure.

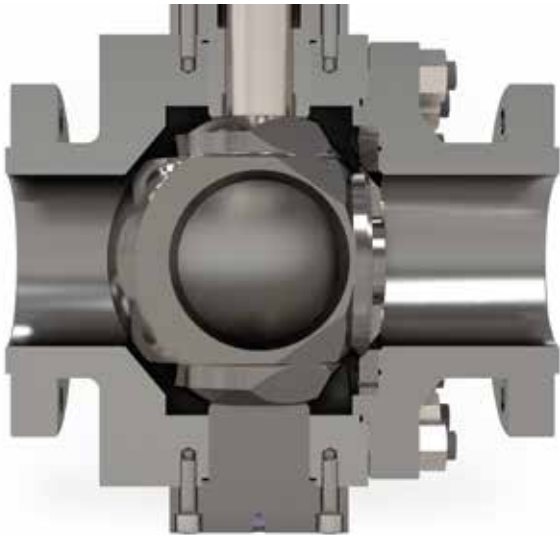

### 5.2 LONG LIFE CYCLE:

The geometrical parameters are optimized to minimize the torque for tight shut-off while eliminating any risk of jamming the seal ring into the seat.

The unique sealing system provides a long-life solution.

An engineered material and coating selection brings a longer life cycle and maintenance free solution.

### 5.3 ZERO-FRICTION:

- Action of triple eccentric movement eliminates seal to seal friction, only in contact at the fully closed position.
- No narrow fluid paths between ball and seat, no risk of erosion.
- Reduced moving parts result in reduced friction.

### 5.4 OPERATION CONCEPT:

AMPO POYAM VALVES Hypercentric ball valve as bases of a triple eccentric design, provides a non-contact seat to seal travelling allowing the flow to withstand the maximum valve capacity. Seal is totally protected in fully open position. The newest seal solution provides a cone in cone sealing mechanical interference bringing the maximum tightening solutions with the lowest wear.

### 5.5 TRUNNION MOUNTED DESIGN:

- Reliable, sturdy trunnion mounted design.
- Reduces stress and increases life expectancy.
- Robust and reliable assembly suitable for high pressures and temperature shut off solution.

### 5.6 METAL-TO-METAL POSITIVE SEALING:

- Zero leakage after cycling.
- No floating seats, no risk of sticking due to contaminated fluids.
- No floating seats, no risk of failure at high temperatures.

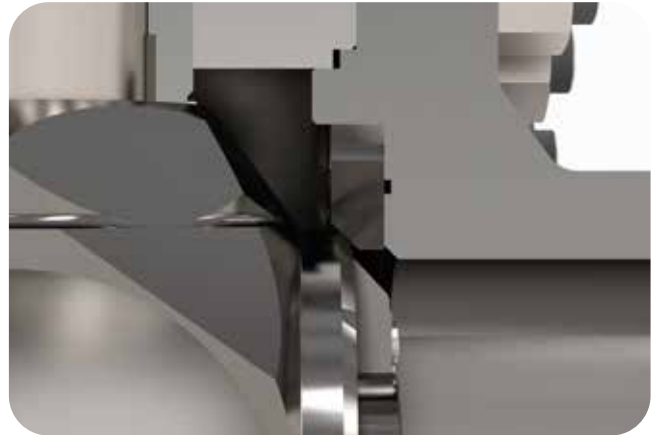

### 5.7 LOW FUGITIVE EMISSION PACKING:

Highly engineered graphite packing rings are provided to avoid emissions to the atmosphere for endurance applications.

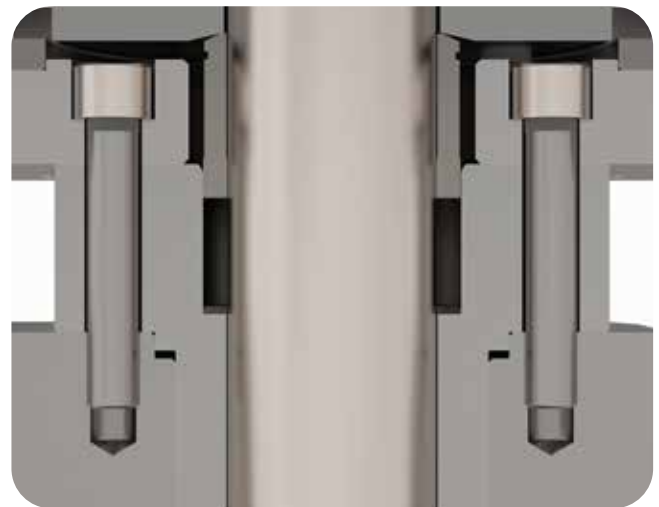

### 5.8 INTRINSICALLY FIRE SAFE:

- No component is detrimentally impacted during fire simulation.
- Able to provide unaffected shut off.

### 5.9 ANTI STATIC DEVICE:

The electrical continuity between all metallic components of body and trim is achieved by an anti-static spring-loaded device.

### 5.10 CONFIGURATIONS:

- Unidirectional or bidirectional seal
- Top or side entry body configuration
- Horizontal or vertical configuration
- Fully metal vs metal + PTFE bushing (up to 200°C)

## 6. QUALIFICATION

AMPO POYAM VALVES values quality and therefore our operating and production processes are implemented and controlled by a quality assurance system, certified since 1991 under the ISO 9001 Standard and accredited by the most important external organizations. Moreover AMPO POYAM VALVES holds international standard approvals and completely fulfills international standard requirements, reinforcing its leading position on the valve industry.

A summary of the most demanded standards is presented hereafter, although the qualification list can be extended upon each customer request:

**General Standards:**

API6D, ISO 14313, ASME B16.34, API 608, ISO 17292, JIS, 2014/68/UE (CE), SIL, B16.5, MSS SP-44, B16.47, B16.10, ISO 5752, B16.25, B16.11, ISO 5210/5211, etc.

**Fire Safe:** API 607 & API 6FA.

**Fugitive Emission:** API 641, API 622, ISO 15848 Part 1&2 up to Class A.

**Testing:** API 598, ISO 5208, ISO 28921 Part 1&2, MSS SP-134, etc.

**Type Approvals (for marine service too):** Bureau Veritas, ABS, Lloyds, TUV, DNV, NORSOK, etc.  
Country based certifications: GOST, TSG, CRN, KGS, 2014/34/EU (ATEX), PESO, etc.



## 7. MATERIAL SELECTION

Material selection is done accordingly based on the AMPO POYAM VALVES long expertise in the field.

### PRESSURE CONTAINING FORGED COMPONENTS:

*(valvebody/bonnets/closure/flanged trunnion)*

Carbon steel or low alloy with partial or full CRA overlay:

- Forged Low Temperature carbon steel ASTM A350 LF2 with Inconel 625 cladding.
- Forged Carbon Steel materials according to ASTM A694, grade F60/F65 modified with Inconel 625 cladding.

Optionally, cast valve bodies shall be considered due to weight saving potential.

Cladding can be applied depending on the service on sliding areas, on the sealing area or wetted areas.

### PRESSURE CONTROLLING COMPONENTS:

- **Stem material options:** High Grades of Martensitic Stainless Steel ASTM A630 H1150D, Super Duplex stainless steel ASTM A182 F55, Austenitic stainless steel ASTM A479 XM19 / Nickel base alloys: Alloy 718 (UNS N07718), Alloy 625 (UNS N07625).

- **Seat rings material options:** Duplex (22%Cr) or Superduplex (25%Cr) stainless steel ASTM A 182 Gr. F51/F53/F55 / Nickel based Alloy 625 / Stainless steel ASTM A182 Gr. 316 (AISI 316).

Hard coatings for closures and seat in tungsten and chrome carbide, 0.2mm HVOF

- **Seal ring material options:** Martensitic Stainless Steel ASTM A182 F6NM, Duplex stainless steel ASTM A182 F51, Inconel Alloy 718.

Electro Niquel Plated for seal treatment 0.025mm.

- **Ball material options:** Duplex (22%Cr) or Superduplex (25%Cr) or Nickel based Alloy 625 / Stainless steel ASTM A182 Gr. 316 (AISI 316).

- **Bolting material options:** ASTM A193 B7 / ASTM A193 B7M. ASTM A194 2H/ASTM A194 2HM. Full NACE requirement.



## 8. AMPO SERVICE

AMPO SERVICE has a wide experience in guaranteeing a **prompt response** (72 hours at site if needed) to customer needs **all over the world** with a highly experienced, customer oriented and specialized team. It provides a wide range of **ad-hoc and high added value services**:

- **MRO SERVICES.** Plug and play valves. Fast track.
- **SPARE PARTS.** Optimized Management Program. Fast track services.
- **TRAINING SERVICES**
- **FIELD ENGINEERING SERVICES (FES):** Consulting services during plant construction. Commissioning and start-up services. Planned shut-down services. Troubleshooting.
- **PREDICTIVE MAINTENANCE SERVICE:** Patented AMPO RCM system (Remote Valve Condition Monitoring Service)
- **PREVENTIVE MAINTENANCE SERVICE:** Maintenance Plan developments.
- **WORLDWIDE REPAIR AND MAINTENANCE CENTERS**
- **TAILORED ENGINEERING SOLUTIONS**
- **MASTER SERVICE AGREEMENTS WITH END USERS**

Our main aim is to fulfill customer needs worldwide with the following key premises: **reliability, safety, trust and efficiency.**



# 9. WORLDWIDE SALES AND MANUFACTURING NETWORK

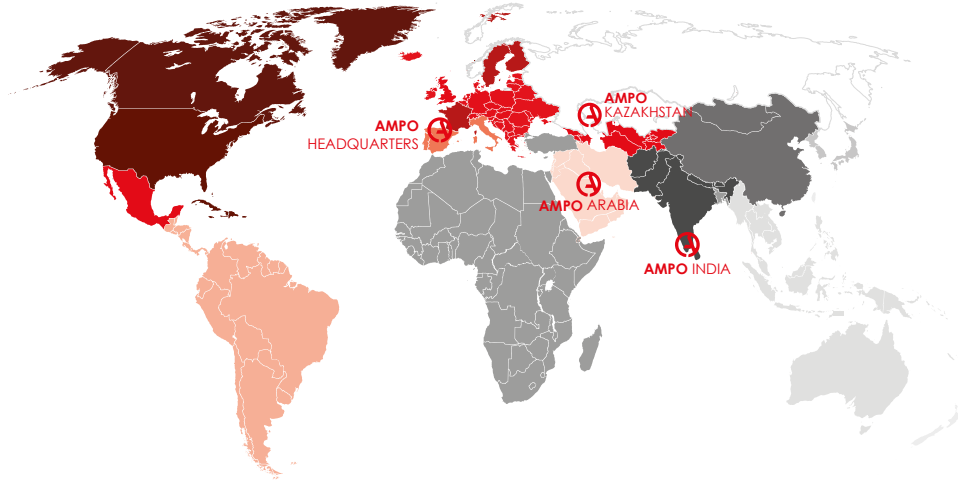

**AMPO Manufacturing plants**  
Idiazabal - Spain  
Coimbatore - India  
Dammam - Saudi Arabia  
Atyrau - Kazakhstan

## SALES MANAGERS

- **Spain & Italy**  
Naiara Aranburu  
naranburu@ampo.com
- **South America**  
Juan Maria Echeverria  
jmecheverria@ampo.com
- **India & Bordering countries**  
Kerman Uriel  
kuriel@ampo.com
- **France and Scandinavia**  
Andrea Navarro  
anavarro@ampo.com
- **Middle East**  
Ander Elola  
aelola@ampo.com
- **Japan & Korea**  
Julen Mugica  
jmugica@ampo.com
- **Mexico, UK, Central Europe and Central Asia**  
Sabin Garcia  
sgarcia@ampo.com
- **China**  
Ustaritz Errondosoro  
usta@ampo.com
- **North America**  
Iñaki Aizpeolea  
inaki@ampo.com
- **Africa & Turkey**  
Mohammed Mehdi  
mmehdi@ampo.com
- **Australasia**  
Ander Janin  
ajanin@ampo.com

## AMPO SERVICE

**AMPO SERVICE Sales Manager**  
Aitor Lizarraga  
alizarraga@ampo.com

## MANUFACTURING PLANTS:

### AMPO HEADQUARTERS

Katea Auzoa s/n. 20213 Idiazabal,  
Gipuzkoa, Spain.  
Tel. +34 943 188 000  
ampo@ampo.com

### AMPO INDIA

SF.No.27/2 & 28/3B, Ponnandampalayam,  
Arasur, Sulur, Coimbatore - 641 659 - India  
Tel. 0422 7140900  
ampoindia@ampo.com

### AMPO ARABIA

#3848 Road 86, Dammam 2nd Industrial city  
Dammam 34326 - 2817, Saudi Arabia  
ampoarabia@ampo.com

### AMPO KAZAKHSTAN

SMP-163, Kabylanbay Batyr street, 7  
Atyrau City, Kazakhstan  
kazakhstan@ampo.com

AMPO is just 1 hour drive away from BILBAO (International Airport) and at the following distances from other important places:  
65 km west of Pamplona/45 km south of San Sebastian/ 70 km south of the French border.

