



Axial Flow Check Valve

Technical brochure

COMPANY PROFILE

AMPO is an **international leader** in highly engineered valves and integrated smart solutions for the most severe applications and industries as well as in stainless steel and high alloy castings.

Through our AMPO SERVICE team **we guarantee a prompt response** to customer needs wherever they are throughout the world: technical support in start-up stages, equipment selection, predictive and preventive maintenance, training, etc.



Fully inhouse manufacturing process



Worldwide references



Project based on people



Innovative spirit



700+ people



In more than 60 countries



Most important partners in the industry



Cutting edge technologies



Our commitment: the best service



Customer focus



Since 1964

CERTIFIED ISO 9001
 ULKAS ISO 9001 001
 CE
 API
 TUV APPROVAL
 LEVITS REGISTER TYPE APPROVAL
 ABS
 TUV Rheinland CERTIFIED
 SILPC Capability
 DNV
 NORSOK
 CERTIFIED ISO 14001
 ULKAS ISO 14001 001

APPLICATION

AXIAL FLOW CHECK VALVES are mainly used **to protect rotating equipment and systems from reverse flow**, in several services, such as cryogenic, high temperature and soft services.

As a result of **over 40 years of experience in the manufacturing of check valves**, AMPO POYAM VALVES is a leading manufacturer of high specification valves for the oil and gas industry.

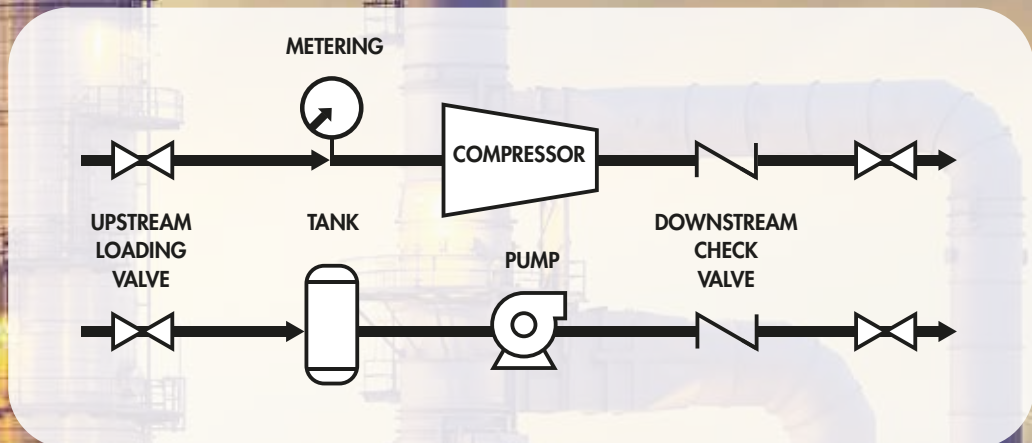

AXIAL FLOW CHECK VALVE



AXIAL FLOW CHECK VALVE

CHARACTERISTICS

- Sizes:** 4" up to 54"
- Pressure:** 150 LBS up to 2500 LBS
- Temperature:** -196°C up to 600°C
- Standards:** API 6D, ASME B.16.34, ASME B.16.5, ASME B.16.25
Fire safe certificate as per API 607 and API 6FA
- Materials:** CF3, CF3M, CF8, CF8C, CF8M, CG8M,
- End connections:** BW, RF, FF, NPT, RTJ, SW; CLAMPS
- Actuation:** SPRING ACTIVATED



WHY CHOOSE OUR AXIAL FLOW CHECK VALVE?



RELIABLE SOLUTION:

- Minimum pressure loss
- Stable operation & water hammer effect avoidance
- Dynamic behavior



ZERO EMISSIONS:

- The absence of a bonnet or any other openings to the environment ensures zero emissions (No leakpath to atmosphere)

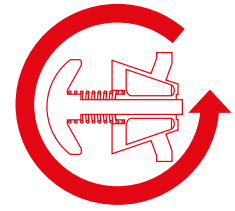

IMMEDIATE DISC REACTION & A RAPID SELF-DAMPENING RESPONSE to noticeable flow reductions, limiting:

- Backflow
- Valve slamming



COMPACT AND LIGHTWEIGHT DESIGN

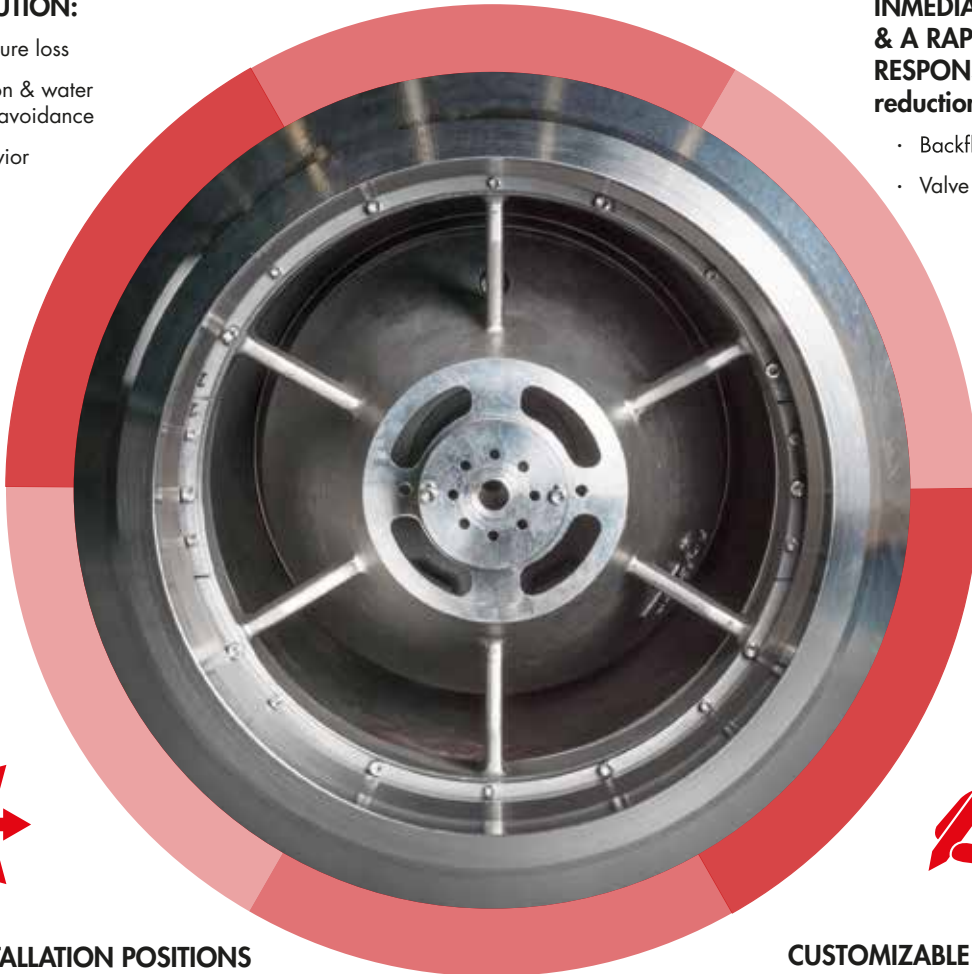

STREAMLINED FLOW PATH FOR QUIET OPERATION

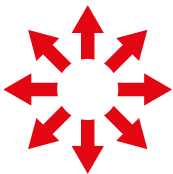

FLEXIBILITY IN INSTALLATION POSITIONS & EASE OF INSTALLATION AND SERVICE:

- The AMPO POYAM VALVES axial flow check valve is suitable for installation in a horizontal, vertical or inclined position.



CUSTOMIZABLE DESIGN:

- The spring is designed for each project and application, considering fluid/flow properties of each service. Moreover, wide variety of materials are available for body and trim components.



MAINTENANCE FREE & LONG SERVICE LIFE DESIGN:

- Due to its non-slam design, the valve is not subjected to extreme shocks associated with typical asymmetric valve designs.
- The valve has no soft parts, seals or o-rings which would wear, cause misalignment or need replacing.
- The metal-to-metal disc seat seal achieves tight shut-off with 100% reliability.



Total reliability and high performance



Minimum maintenance costs



Optimization in spare parts management

TECHNICAL FEATURES

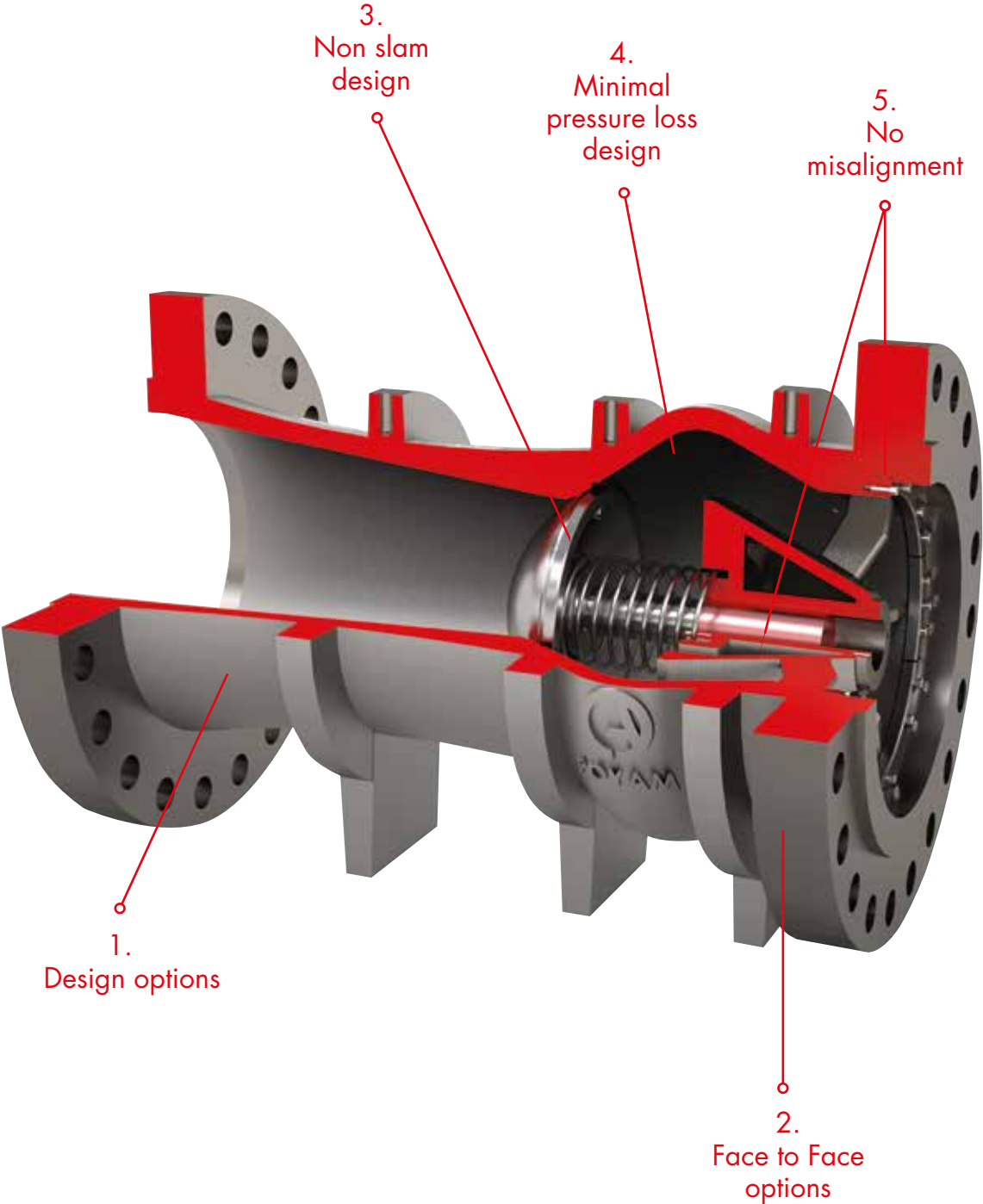

1. DESIGN OPTIONS:

Valve guidance system is only size dependant. **Back-guided design** is applied up to 30 inches. For valves larger than 30 inches **double-guided design** is applied to maintain sealing and non-slam characteristics.

Back-Guided Design



Double-Guided Design



2. FACE TO FACE OPTIONS:

BACK-GUIDED DESIGN:

For back-guided valves short pattern (AMPO standard) and long pattern (API 6D) face to face options are available.

DOUBLE-GUIDED DESIGN:

For double guided design there is only one face to face option (AMPO standard).

Short Pattern



BW Design



RF Design



BW Design

Long Pattern



BW Design



RF Design



RF Design

3. NON SLAM DESIGN:

The design allows the disc to be always in the optimum position:

- Fully opened at normal flow.
- Proportionally more closed as the flow reduces.
- Fully closed if there is any attempt of reversal flow.

When fluid velocity decreases, and the force pressing on the valve disc diminishes, the helical spring which is designed specifically for each process and application, will move the disc towards the closed position.



AMPO POYAM VALVES' Axial Flow Check Valve do not require gravity or fluid flow for its closure operation. Instead of that, as the forward velocity of the fluid slows, the spring assist on the valve starts to close the disc.

By the time the forward velocity of the fluid decreased to zero, the valves' disc has reached the seat and the valve is closed, due to the spring assist, the disc must move.

Consequently, with reverse flow removed, the forces required to produce water hammer on both the upstream and downstream sides of the valves are entirely eliminated.

The shock waves that are usually generated inside a pipe when a fluid is stopped brusquely by an object such as a valve disc, cause the WATER HAMMER EFFECT. As a result of this effect, noise, vibration and hammering pipe sounds can lead to equipment damages.

With the spring assisted AMPO POYAM VALVES' Axial Flow Check Valve this effect is eliminated or greatly minimized.

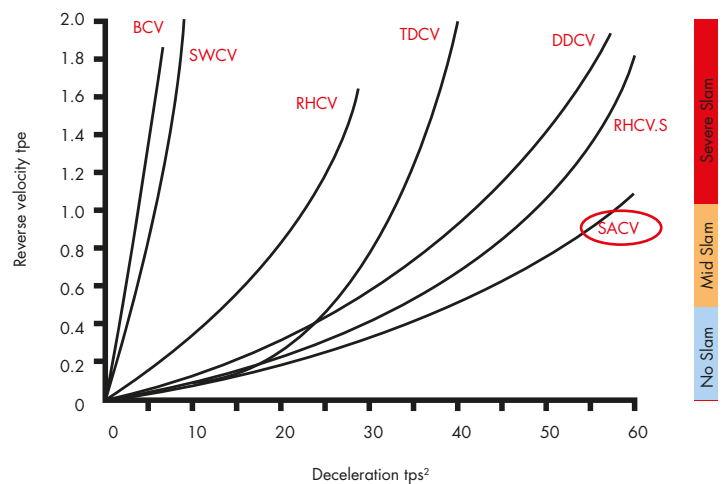

BCV (ball check valve), DDCV (dual disc check valve), RHCV (resilient hinge check valve), RHCV.S (resilient hinge check valve with spring), SACV (silent oxid check valve), SWCV (swing check valve), TDCV (tilted disc check valve).

4. MINIMAL PRESSURE LOSS DESIGN:

Valves are designed to guarantee the minimum pressure loss through the valve.

- The internal profile of the valve body and the disc are designed to closely follow the precisely contoured surface of the diffuser.
- The velocity of the fluid will increase as it approaches the constricting throat of the valve.

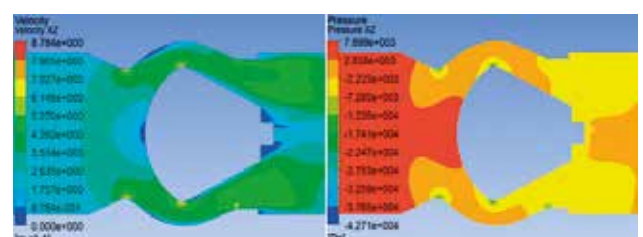

5. NO MISALIGNMENT:

Zero possibilities for misalignment due to a perfect guidance between the diffuser and the body. Moreover, the disc and the stem are manufactured in an unique piece with an accurate machining.

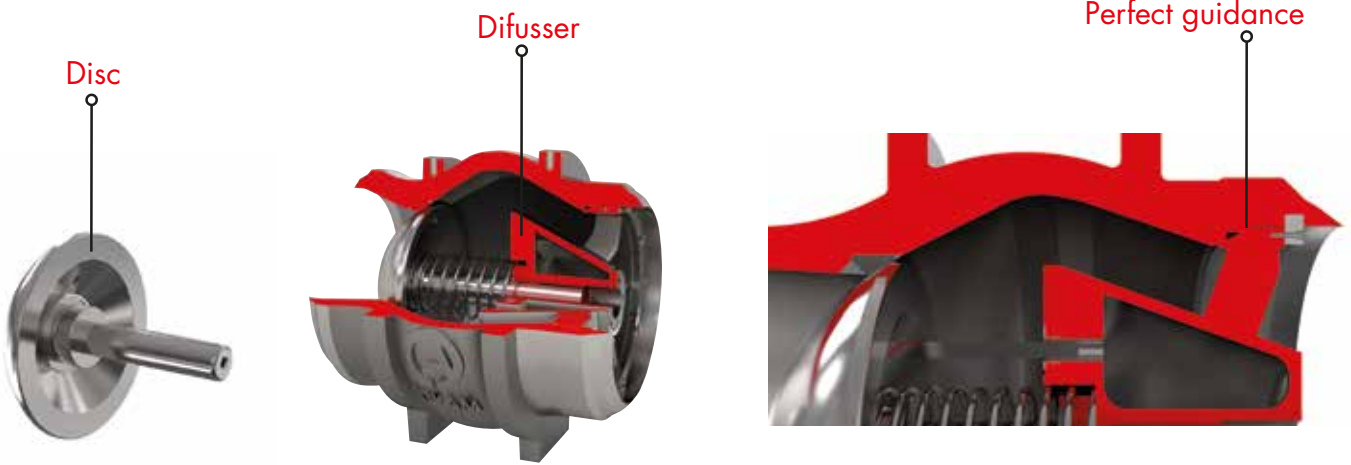

6. INSTALLATION GUIDELINES FOR EQUIPMENT PROTECTION:

In order to guarantee an excellent protection of equipments and the reliability of our valves, AMPO POYAM VALVES Engineering team provides technical guidelines for a proper installation of axial flow check valves, based on each customer requirements.

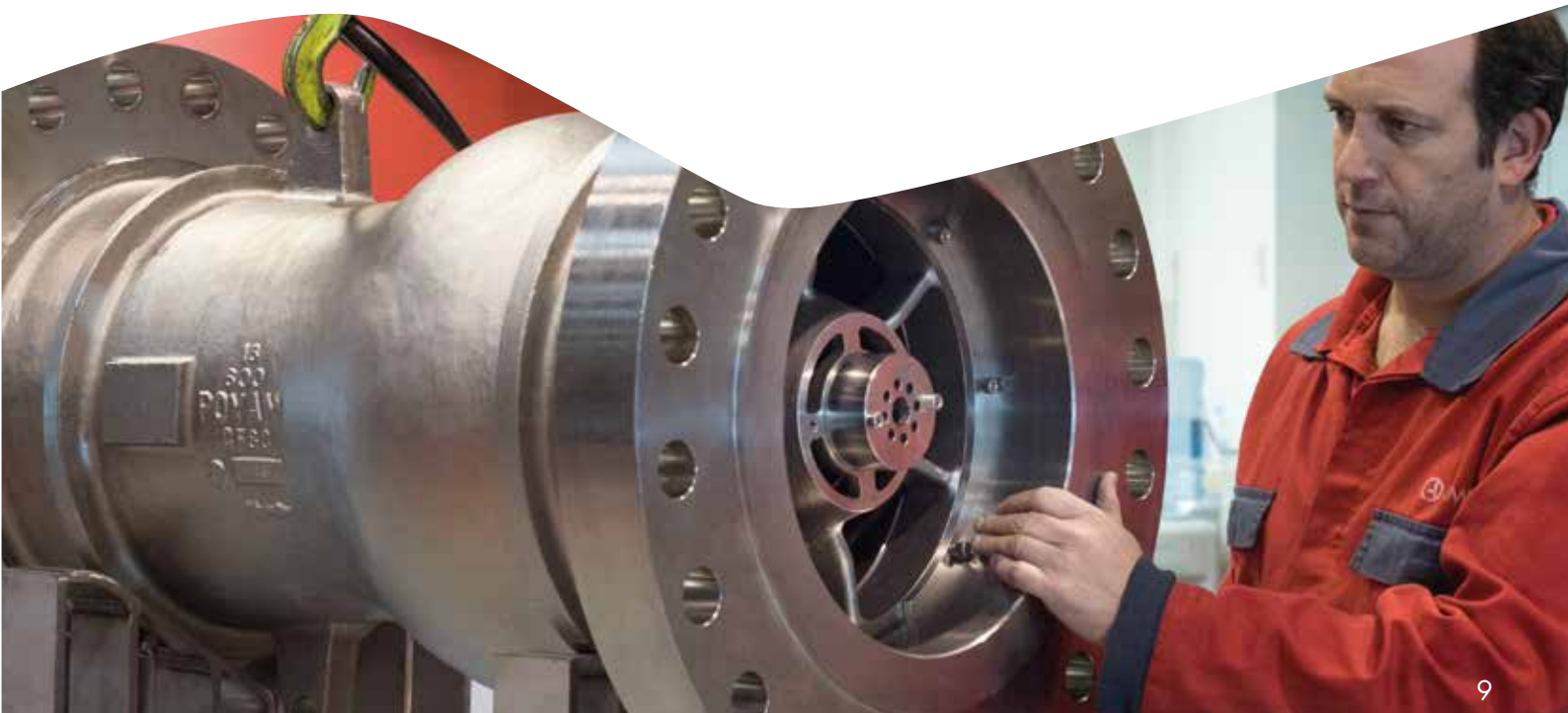

MATERIAL SELECTION

CRYOGENIC SERVICE

Sample drawing

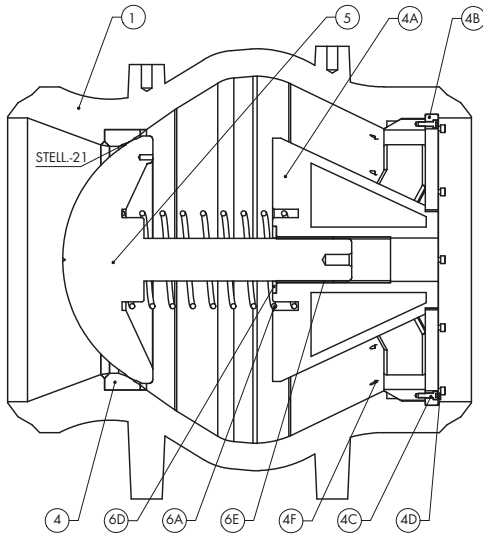

CF8M-316

NO.	PART	MATERIAL
1	BODY	ASTM A 351 CF8M
4	SEAT	ASTM A 479 Gr.316/ASTM A 351 CF8M + STELL.-21
4A	DIFFUSER	ASTM A 351 CF8M
4B	RETAINING RING	ASTM A 479 Gr. 316
4C	BOLT	ASTM A 479 Gr. 316
4D	BOLT	ASTM A 479 Gr. 316
4F	BOLT	ASTM A 479 Gr. 316
5	DISC	ASTM A 351 CF8M + STELL.-21
6A	SPRING	INCONEL X-750
6D	WASHER	ASTM A 479 Gr. 316
6E	BUSHING	316 + PTFE

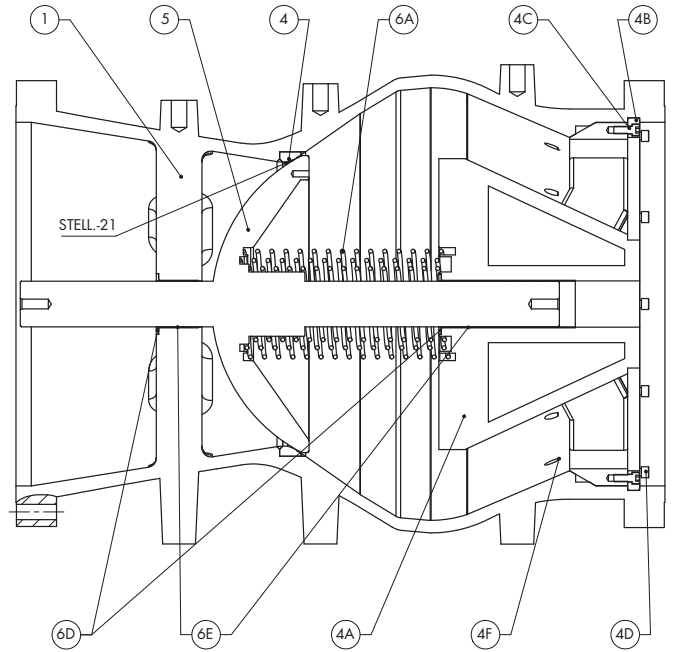

CF3M-316L

NO.	PART	MATERIAL
1	BODY	ASTM A 351 CF3M
4	SEAT	ASTM A 479 Gr.316L/ASTM A 351 CF3M + STELL.-21
4A	DIFFUSER	ASTM A 351 CF3M
4B	RETAINING RING	ASTM A 479 Gr. 316L
4C	BOLT	ASTM A 479 Gr. 316L
4D	BOLT	ASTM A 479 Gr. 316L
4F	BOLT	ASTM A 479 Gr. 316L
5	DISC	ASTM A 351 CF3M + STELL.-21
6A	SPRING	INCONEL X-750
6D	WASHER	ASTM A 479 Gr. 316L
6E	BUSHING	316 + PTFE

CF8-304

NO.	PART	MATERIAL
1	BODY	ASTM A 351 CF8
4	SEAT	ASTM A 479 Gr.304/ASTM A 351 CF8 + STELL.-21
4A	DIFFUSER	ASTM A 351 CF8
4B	RETAINING RING	ASTM A 479 Gr. 304
4C	BOLT	ASTM A 479 Gr. 304
4D	BOLT	ASTM A 479 Gr. 304
4F	BOLT	ASTM A 479 Gr. 304
5	DISC	ASTM A 351 CF8 + STELL.-21
6A	SPRING	INCONEL X-750
6D	WASHER	ASTM A 479 Gr. 304
6E	BUSHING	316 + PTFE

CF3-304L

NO.	PART	MATERIAL
1	BODY	ASTM A 351 CF3
4	SEAT	ASTM A 479 Gr.304L/ASTM A 351 CF3M + STELL.-21
4A	DIFFUSER	ASTM A 351 CF3
4B	RETAINING RING	ASTM A 479 Gr. 304L
4C	BOLT	ASTM A 479 Gr. 304L
4D	BOLT	ASTM A 479 Gr. 304L
4F	BOLT	ASTM A 479 Gr. 304L
5	DISC	ASTM A 351 CF3 + STELL.-21
6A	SPRING	INCONEL X-750
6D	WASHER	ASTM A 479 Gr. 304L
6E	BUSHING	316 + PTFE

GENERAL SERVICE

Sample drawing

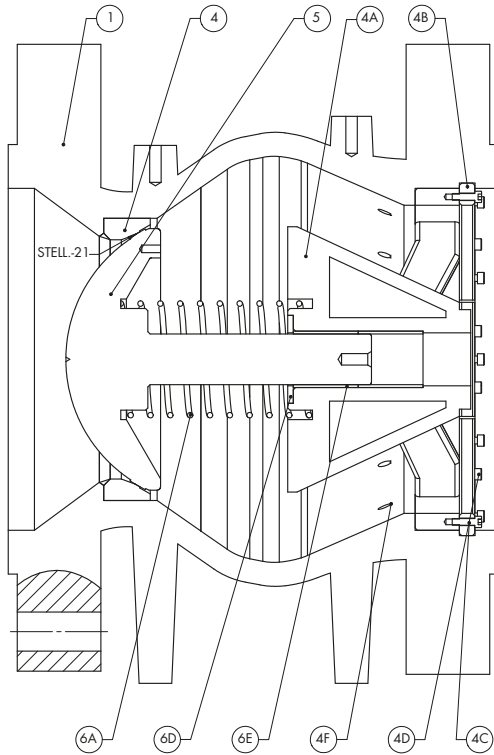

WCB-F6

NO.	PART	MATERIAL
1	BODY	ASTM A 216 WCB
4	SEAT	ASTM A 105N + STELL.-21
4A	DIFFUSER	ASTM A 216 WCB
4B	RETAINING RING	ASTM A 479 Gr. 410
4C	BOLT	ASTM A 479 Gr. 410
4D	BOLT	ASTM A 479 Gr. 410
4F	BOLT	ASTM A 479 Gr. 410
5	DISC	ASTM A 216 WCB + STELL.-21
6A	SPRING	INCONEL X-750
6D	WASHER	ASTM A 479 Gr. 410
6E	BUSHING	316 + PTFE

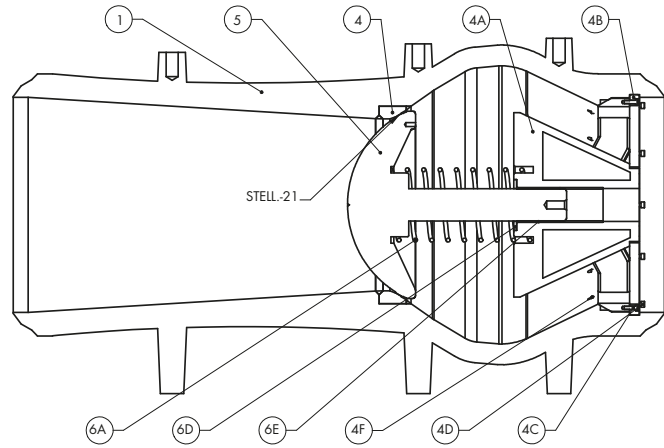

WCB-316

NO.	PART	MATERIAL
1	BODY	ASTM A 216 WCB
4	SEAT	ASTM A 479 Gr.316 + STELL.-21
4A	DIFFUSER	ASTM A 216 WCB
4B	RETAINING RING	ASTM A 479 Gr. 316
4C	BOLT	ASTM A 479 Gr. 316
4D	BOLT	ASTM A 479 Gr. 316
4F	BOLT	ASTM A 479 Gr. 316
5	DISC	ASTM A 216 WCB + STELL.-21
6A	SPRING	INCONEL X-750
6D	WASHER	ASTM A 479 Gr. 316
6E	BUSHING	316 + PTFE

WCB-FBE-316

NO.	PART	MATERIAL
1	BODY	ASTM A 216 WCB (FBE Coating)
4	SEAT	ASTM A 479 Gr. 316 + STELL.-21
4A	DIFFUSER	ASTM A 351 CF8M
4B	RETAINING RING	ASTM A 479 Gr. 316
4C	BOLT	ASTM A 479 Gr. 316
4D	BOLT	ASTM A 479 Gr. 316
4F	BOLT	ASTM A 479 Gr. 316
5	DISC	ASTM A 216 WCB + STELL.-21
6A	SPRING	INCONEL X-750
6D	WASHER	ASTM A 479 Gr. 316
6E	BUSHING	316 + PTFE

Gr4-S31803

NO.	PART	MATERIAL
1	BODY	ASTM A 995 Gr4A
4	SEAT	ASTM A240 (UNS S31803) + STELL.-21
4A	DIFFUSER	ASTM A 995 Gr4A
4B	RETAINING RING	ASTM A240 (UNS S31803)
4C	BOLT	ASTM A240 (UNS S31803)
4D	BOLT	ASTM A240 (UNS S31803)
4F	BOLT	ASTM A240 (UNS S31803)
5	DISC	ASTM A 995 Gr4A
6A	SPRING	INCONEL X-750
6D	WASHER	ASTM A240 (UNS S31803)
6E	BUSHING	316 + PTFE

HIGH TEMPERATURE SERVICE

Sample drawing

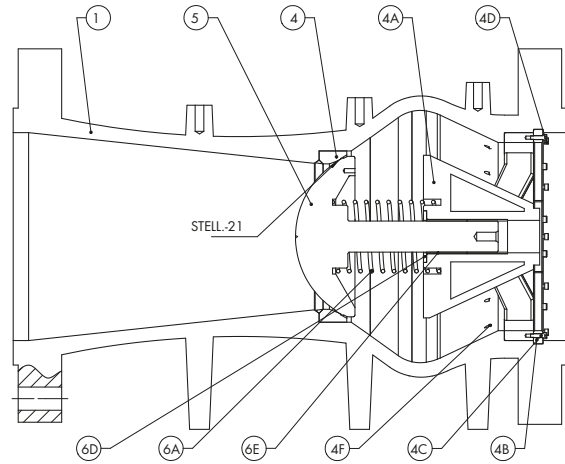
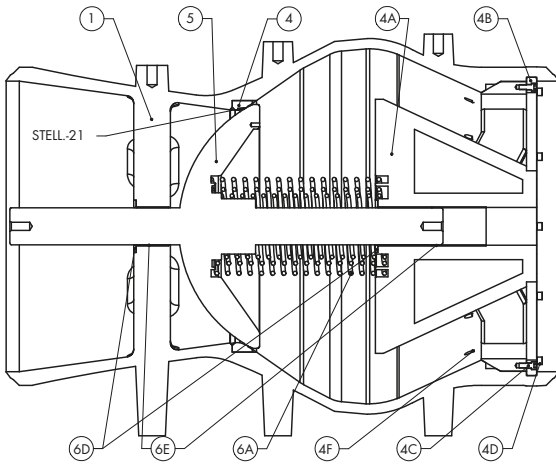

CF8C-347

NO.	PART	MATERIAL
1	BODY	ASTM A 351 CF8C
4	SEAT	ASTM A 351 CF8C + STELL.-21
4A	DIFFUSER	ASTM A 351 CF8C
4B	RETAINING RING	ASTM A 479 347
4C	BOLT	ASTM A 479 347
4D	BOLT	ASTM A 479 347
4F	BOLT	ASTM A 479 347
5	DISC	ASTM A 351 CF8C + STELL.-21
6A	SPRING	INCONEL X-750
6D	WASHER	ASTM A 479 347
6E	BUSHING	INCONEL 625 + DURITEX

WC6-F6

NO.	PART	MATERIAL
1	BODY	ASTM A 217 WC6
4	SEAT	ASTM A 105N + STELL.-21
4A	DIFFUSER	ASTM A 217 WC6
4B	RETAINING RING	ASTM A 479 Gr. 410
4C	BOLT	ASTM A 479 Gr. 410
4D	BOLT	ASTM A 479 Gr. 410
4F	BOLT	ASTM A 479 Gr. 410
5	DISC	ASTM A 217 WC6 + STELL.-21
6A	SPRING	INCONEL X-750
6D	WASHER	ASTM A 479 Gr. 410
6E	BUSHING	INCONEL 625 + DURITEX

LCB-316

NO.	PART	MATERIAL
1	BODY	ASTM A 352 LCB
4	SEAT	ASTM A 479 Gr.316/ASTM A 351 CF8M + STELL.-21
4A	DIFFUSER	ASTM A 351 CF8M
4B	RETAINING RING	ASTM A 479 Gr. 316
4C	BOLT	ASTM A 479 Gr. 316
4D	BOLT	ASTM A 479 Gr. 316
4F	BOLT	ASTM A 479 Gr. 316
5	DISC	ASTM A 351 CF8M + STELL.-21
6A	SPRING	INCONEL X-750
6D	WASHER	ASTM A 479 Gr. 316
6E	BUSHING	INCONEL 625 + DURITEX

WCB-316

NO.	PART	MATERIAL
1	BODY	ASTM A 216 WCB
4	SEAT	ASTM A 479 Gr.316 + STELL.-21
4A	DIFFUSER	ASTM A 216 WCB
4B	RETAINING RING	ASTM A 479 Gr. 316
4C	BOLT	ASTM A 479 Gr. 316
4D	BOLT	ASTM A 479 Gr. 316
4F	BOLT	ASTM A 479 Gr. 316
5	DISC	ASTM A 216 WCB + STELL.-21
6A	SPRING	INCONEL X-750
6D	WASHER	ASTM A 479 Gr. 316
6E	BUSHING	INCONEL 625 + DURITEX

C12-CA6NM

NO.	PART	MATERIAL
1	BODY	ASTM A217 C12
4	SEAT	ASTM A487 CA-6NM + STELL.-21
4A	DIFFUSER	ASTM A217 C12
4B	RETAINING RING	ASTM A487 CA-6NM
4C	BOLT	ASTM A487 CA-6NM
4D	BOLT	ASTM A487 CA-6NM
4F	BOLT	ASTM A487 CA-6NM
5	DISC	ASTM A217 C12 + STELL.-21
6A	SPRING	INCONEL X-750
6D	WASHER	ASTM A487 CA-6NM
6E	BUSHING	INCONEL 625 + DURITEX

DIMENSIONAL TABLES

BACK-GUIDED BW DESIGN

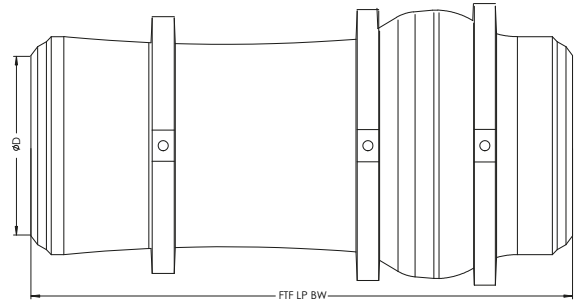
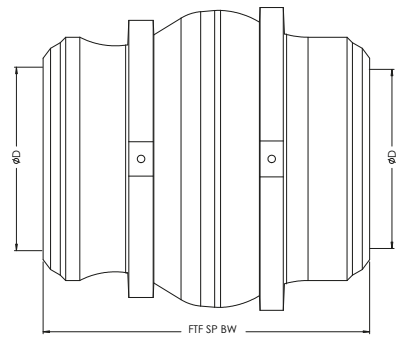

SIZE	FTF Short pattern (AMPO STD)	FTF Long pattern (API6D)	Ø D	WEIGHT Short pattern (AMPO STD)	WEIGHT Long pattern (API6D)
150 LBS					
4	174	292	102,3	22	34
6	265	356	154,1	31	36
8	305	495	205,0	58	73
10	380	622	254,5	103	131
12	450	699	307,1	150	186
14	490	787	339,8	194	245
16	560	864	390,6	286	350
18	630	978	441,4	398	492
20	700	978	495,3	514	602
22	774	1176	546,1	696	854
24	835	1295	596,9	844	1056
26	908	1374	644,6	1081	1325
28	975	1448	695,4	1283	1578
30	1045	1524	746,2	1598	1951
600 LBS					
4	178	432	102,3	29	36
6	265	559	154,1	37	62
8	305	660	202,7	70	114
10	380	787	254,5	133	209
12	450	838	303,2	220	318
14	490	889	336,5	278	401
16	560	991	387,3	410	581
18	630	1092	438,1	568	798
20	700	1194	488,9	758	1056
22	771	1314	539,7	1055	1470
24	835	1397	590,5	1266	1765
26	902	1511	635,0	1667	2305
28	975	1600	685,8	2034	2832
30	1045	1651	736,6	2476	3385
1500 LBS					
4	238	546	102,3	58	70
6	306	705	146,3	82	119
8	344	832	193,7	108	229
10	394	991	242,9	188	409
12	451	1130	288,9	306	654
14	494	1257	317,5	374	830
16	567	1384	363,5	608	1244
18	632	1537	409,5	894	1700
20	697	1664	455,6	1261	2443
22	754	1815	501,6	1464	2999
24	838	1943	547,7	1769	3734

SIZE	FTF Short pattern (AMPO STD)	FTF Long pattern (API6D)	Ø D	WEIGHT Short pattern (AMPO STD)	WEIGHT Long pattern (API6D)
300 LBS					
4	178	356	102,3	24	29
6	265	444	154,1	36	49
8	305	533	205,0	64	86
10	380	622	254,5	114	150
12	450	711	307,1	179	228
14	490	838	339,8	252	330
16	560	864	390,6	338	427
18	630	978	438,1	461	584
20	700	1016	488,9	616	750
22	771	1229	539,7	790	1024
24	835	1346	590,5	1027	1338
26	902	1430	641,3	1181	1553
28	975	1499	692,1	1352	1798
30	1045	1594	742,9	1679	2236
900 LBS					
4	238	457	102,3	42	49
6	306	610	154,1	55	74
8	344	737	202,7	86	151
10	394	838	254,5	149	256
12	451	965	303,2	236	410
14	494	1029	325,4	312	527
16	610	1130	373,1	502	613
18	632	1219	428,7	649	1043
20	697	1321	477,8	878	1397
22	761	1453	533,4	1176	1704
24	838	1549	574,6	1260	2106
26	879	1668	635,0	1868	2558
28	939	1776	679,4	2322	3052
30	998	1884	730,2	2815	3590
2500 LBS					
4	253	673	87,3	77	118
6	324	914	131,8	115	199
8	367	1022	182,6	148	380
10	424	1270	230,2	252	718
12	486	1422	266,7	359	1069
14	532	1633	292,1	482	-
16	610	1826	333,3	734	-
18	682	2018	377,9	1042	-
20	752	2211	419,1	1403	-
22	752	2403	463,5	-	-
24	904	2596	504,9	2431	-

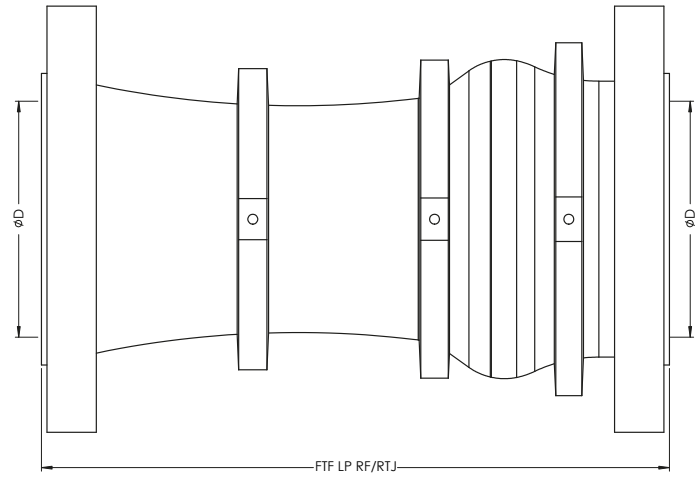
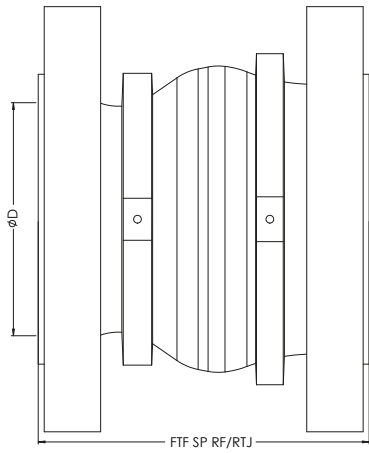

BACK-GUIDED RF & RTJ DESIGNS

SIZE	FTF Short pattern (AMPO STD) RF	FTF Long pattern (API6D) RF	FTF Short pattern (AMPO STD) RTJ	FTF Long pattern (API6D) RTJ	Ø D	WEIGHT Short pattern (AMPO STD)	WEIGHT Long pattern (API6D)
150 LBS							
4	167	292	191	305	102,3	35	46
6	253	356	266	368	154,1	36	53
8	295	495	308	508	205,0	84	100
10	365	622	378	635	254,5	139	167
12	435	699	448	711	307,1	204	242
14	475	787	488	800	339,8	269	320
16	545	864	558	876	390,6	379	445
18	610	978	623	991	441,4	497	594
20	675	978	688	991	495,3	641	733
22	750	1176	751	1172	546,1	865	979
24	810	1295	823	1308	596,9	1018	1235
26	880	1374	875	1364	644,6	1327	1457
28	945	1448	937	1460	695,4	1590	1732
30	1010	1524	999	1556	746,2	1945	2032
600 LBS							
4	171	432	171	435	102,3	43	54
6	253	559	256	562	154,1	102	127
8	295	660	298	664	202,7	167	210
10	365	787	368	791	254,5	295	368
12	435	838	438	841	303,2	408	504
14	475	889	478	892	336,5	506	625
16	545	991	548	994	387,3	732	900
18	610	1092	613	1095	438,1	956	1184
20	675	1194	681	1200	488,9	1250	1544
22	746	1314	754	1322	539,7	1634	2042
24	810	1397	819	1407	590,5	1976	2466
26	874	1511	884	1521	635,0	2455	3083
28	945	1600	958	1613	685,8	2958	3744
30	1010	1651	1023	1664	736,6	3473	4368
1500 LBS							
4	235	546	238	549	102,3	86	108
6	300	705	306	711	146,3	204	262
8	335	832	344	841	193,7	346	461
10	385	991	394	1000	242,9	589	799
12	435	1130	451	1146	288,9	902	1240
14	475	1257	494	1276	317,5	1196	1636
16	545	1384	567	1407	363,5	1667	2287
18	610	1537	632	1559	409,5	2178	3044
20	675	1664	697	1686	455,6	2962	4140
22	727	1815	754	1842	501,6	3698	5204
24	810	1943	838	1972	547,7	4586	6484

SIZE	FTF Short pattern (AMPO STD) RF	FTF Long pattern (API6D) RF	FTF Short pattern (AMPO STD) RTJ	FTF Long pattern (API6D) RTJ	Ø D	WEIGHT Short pattern (AMPO STD)	WEIGHT Long pattern (API6D)
300 LBS							
4	171	356	184	371	102,3	36	43
6	253	444	269	460	154,1	72	85
8	295	533	311	549	205,0	118	142
10	365	622	381	638	254,5	194	230
12	435	711	451	727	307,1	294	344
14	475	838	491	854	339,8	410	488
16	545	864	561	879	390,6	536	626
18	610	978	626	994	438,1	702	828
20	675	1016	694	1035	488,9	908	1048
22	746	1229	767	1250	539,7	1165	1403
24	810	1346	832	1368	590,5	1470	1786
26	874	1430	896	1453	641,3	1714	2089
28	945	1499	970	1524	692,1	1986	2438
30	1010	1594	1035	1619	742,9	2398	2956
900 LBS							
4	235	457	238	460	102,3	62	74
6	303	610	306	613	154,1	136	166
8	341	737	344	740	202,7	239	302
10	391	838	394	841	254,5	370	472
12	448	965	451	968	303,2	532	701
14	485	1029	494	1038	325,4	653	862
16	558	1130	610	1140	373,1	835	1152
18	619	1219	632	1232	428,7	1225	1609
20	684	1321	697	1334	477,8	1588	2090
22	739	1453	761	1453	533,4	2119	2730
24	819	1549	838	1568	574,6	2635	3455
26	852	1668	879	1668	635,0	3216	4073
28	909	1776	939	1795	679,4	3893	4850
30	966	1884	998	1904	730,2	4566	5698
2500 LBS							
4	295	673	304	683	87,3	236	298
6	390	914	403	927	131,8	402	505
8	430	1022	446	1038	182,6	614	817
10	540	1270	562	1292	230,2	1164	1550
12	595	1422	617	1445	266,7	1632	2237
14	675	1633	702	1662	292,1	-	-
16	750	1826	780	1858	333,3	-	-
18	825	2018	859	2055	377,9	-	-
20	900	2211	937	2251	419,1	-	-
22	975	2403	1016	2448	463,5	-	-
24	1050	2596	1094	2644	504,9	-	-

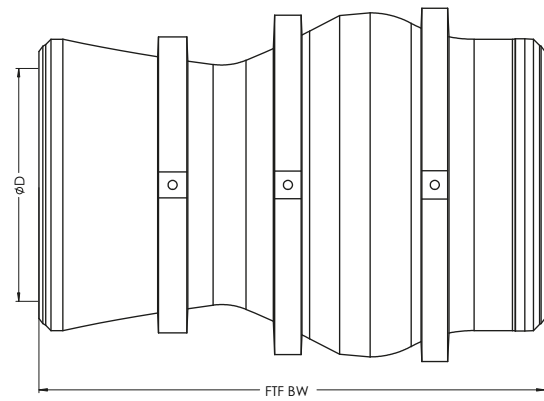
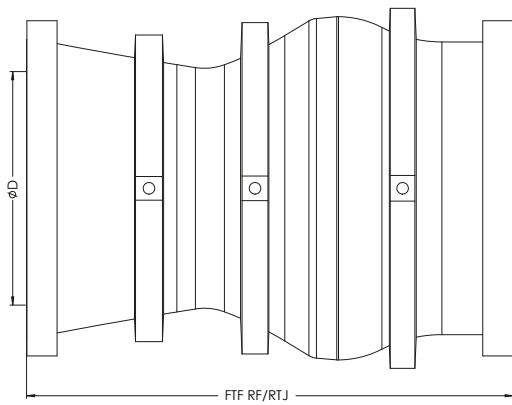

DOUBLE-GUIDED BW DESIGN

SIZE	FTF (AMPO STD.) BW	Ø D	WEIGHT (AMPO STD.)
150 LBS			
32	1614,5	793,7	2660
34	1675	844,5	3163
36	1760	895,3	3650
38	1818	946,1	4331
40	1912	996,9	5312
42	1988	1047,7	5790
44	2034	1098,5	6414
46	2105,5	1149,3	7538
48	2189	1200,1	8473
50	2247	1250,9	9576
52	2317,5	1295,4	10770
54	2389,5	1346,2	11905
300 LBS			
32	1591,5	793,7	3360
34	1641,5	844,5	3858
36	1742	895,3	4511
38	1787,5	946,1	5158
40	1900	996,9	6433
42	1979	1047,7	7060
44	2007	1098,5	7843
46	2080	1149,3	8993
48	2189	1200,1	10424
50	2226	1250,9	10903
52	2297	1295,4	12342
600 LBS			
32	1587,5	781,0	4274
34	1602,5	831,8	4828
36	1774	876,3	5863
38	1781,5	939,8	6649
40	1971	990,6	7481
42	2064	1041,4	9377
44	2048,5	1092,2	10421
46	2135	1143,0	12172
48	2333	1193,8	13860
50	2312	1244,6	15480
900 LBS			
32	1353,5	777,8	4574
34	1437	828,6	5233
36	1519,5	876,3	6362
38	1607,5	939,8	7463
40	1683	990,6	8705
42	1766,5	1041,4	9888
44	1850	1092,2	11282
46	1945	1143,0	12728
48	2017,5	1193,8	14338

DOUBLE-GUIDED RF & RTJ DESIGNS

SIZE	FTF (AMPO STD.) RF	FTF (AMPO STD.) RTJ	Ø D	WEIGHT (AMPO STD.)
150 LBS				
32	1563	1535,5	793,7	3060
34	1622,5	1601	844,5	3556
36	1708,5	1666	895,3	4142
38	1760,5	1729	946,1	4804
40	1853	1838	996,9	5441
42	1921,5	1858	1047,7	6328
44	1967,5	1924	1098,5	7348
46	2036	1990,5	1149,3	8238
48	2137,5	2054,5	1200,1	9185
50	2272,5	2118,5	1250,9	10499
52	2243,5	2181,5	1295,4	11818
54	2310,5	2248,5	1346,2	13110
300 LBS				
32	1540	1582,5	793,7	3989
34	1588,5	1626,5	844,5	4238
36	1690,5	1734	895,3	4885
38	1728,5	1768	946,1	5608
40	1838	1836,5	996,9	6373
42	1908,5	1907	1047,7	7136
44	1935,5	1979,5	1098,5	8153
46	2010	2055,5	1149,3	9386
48	2130,5	2120	1200,1	11162
50	2141	2189,5	1250,9	11887
52	2209	2257,5	1295,4	13018
600 LBS				
32	1536	1560	781,0	4810
34	1602,5	1623,5	831,8	5662
36	1722,5	1746,5	876,3	6991
38	1781,5	1803	939,8	7403
40	1909	1889,5	990,6	8335
42	1997,5	1978	1041,4	9995
44	2043,5	2069,5	1092,2	10640
46	2135	2165	1143,0	12409
48	2274,5	2247	1193,8	13978
50	2303	2334,5	1244,6	15917
900 LBS				
32	1303,5	1353,5	777,8	6314
34	1384	1437	828,6	7409
36	1463,5	1519,5	876,3	8790
38	1547	1607,5	939,8	9758
40	1619,5	1683	990,6	10897
42	1698,5	1766,5	1041,4	12582
44	1799	1850	1092,2	14191
46	1869,5	1945	1143,0	15881
48	1939	2017,5	1193,8	17734

“Due to engineering activities, all the dimensions and weights could be subjected to changes by AMPO POYAM VALVES without any notification. Therefore, please consult us for confirmation on the below data as well as for other dimensions and weights not reported in the tables”.

AMPO SERVICE

- Predictive and preventive maintenance
- Technical support
- Technical training
- Valve condition monitoring
- Spare parts and valve supply

On-site support within the shortest time.

Experience in executing global maintenance service for complete projects.



Commitment made of steel

AMPO HEADQUARTERS

Katea Auzoa s/n. 20213 Idiazábal,
Gipuzkoa, Spain.

Tel. +34 943 188 000

Fax +34 943 188 130

www.ampo.com ampo@ampo.com